

CRUNCHES KRATOS

Artikelnummer Kleuropties

- Geschikt voor verschillende buikspieroefeningen.
- Denk hierbij aan crunches, side crunches, dragon flag en decline & incline push-ups.
- Fine structure coating biedt extra grip.
- Stevige ligging door PE bordesplaat met rubberen toplaag.
- Ideaal te combineren met andere Kratos-structuren.
- Voldoet aan NEN-EN16630.

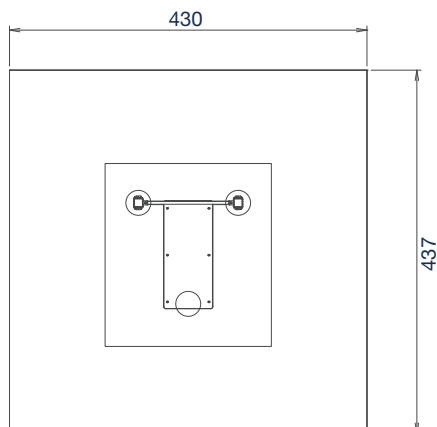

700119-40FS

geen kleuroptie

