

► Recreatief buiten sporten



BACK

Artikelnummer

Kleuropties

- Degelijk fitnessstoestel voor versterken van rug, schouder en biceps.
- Maakt gebruik van eigen lichaamsgewicht als tegengewicht. Stoel gaat omhoog bij krachtsinspanning met armen.
- Voorzien van comfortabel gecoat rubberen rug- en zitvlak.
- De basis bij deze oefening is het herhalen van de training zonder gewicht te verhogen.
- Uiteinden van rubber bieden aangename grip.

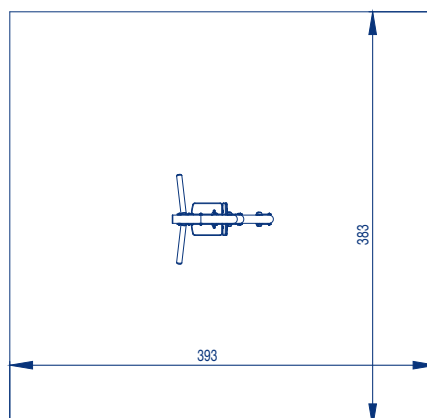

718461-86

geen kleuroptie

